

Series 800 and 1000 Tubular Resistors Product Information



Tubular Resistors – Series 800 and 1000

Series 800 and 1000 Tubular Non-Inductive Bulk Ceramic Resistors provide excellent performance for high peak power or high-energy pulses. Bulk construction advantageously produces an inherently non-inductive resistor; and it allows energy and power to be uniformly distributed through the

entire ceramic resistor body – there is no film or wire to fail. We offer a full line of rugged, reliable ceramic resistors.

We offer three distinctly different ceramic materials to afford the designer with unique components to meet the most demanding requirements:

Type SP resistors are composed of materials that withstand high operating temperatures resulting in high power dissipation. Maximum continuous operating temperature is specified at 350°C. This type is suitable for use in oil without an oil-resistant coating.

Type AS resistors are best suited for high energy and voltage pulse applications. Maximum continuous operating temperature is specified at 230°C. The standard dielectric coating is recommended for use in air, and the oil-resistant coating is recommended for use in oil.

Type A is a high-power non-inductive resistor used when high resistance is required.

Global bulk ceramic resistors are problem solvers for:

Type SP

- Motor drive circuits
- Snubber circuits
- High-frequency circuits
- RF dummy loads
- Dynamic braking
- Transformer protection
- Harmonic filter

Type AS

- Impulse generators
- High-voltage circuits
- X-ray equipment
- High voltage power supplies
- Laser/Imaging equipment
- Capacitor charge/discharge

Type A

- Bleeder
- Capacitor charge/discharge
- ... just to name a few uses.

Ordering Information

Part Numbering System

Example Part Number: 890AS101KDS **890AS** **101** **K** **DS** ← **Terminal End Options**

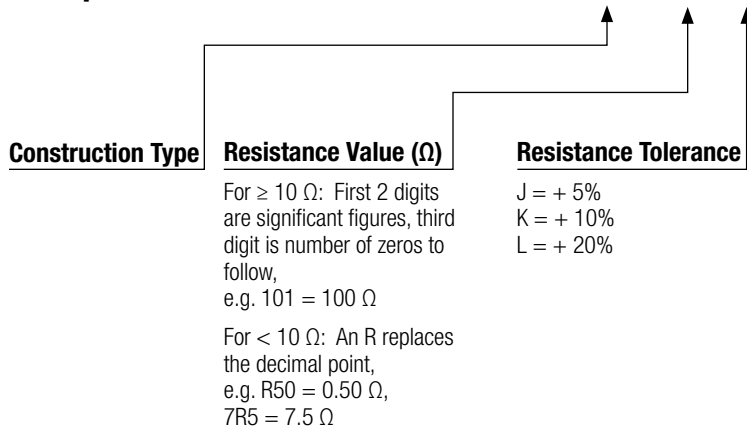

SP	No Suffix = Standard aluminum metalized ends
	No-arc terminal not available on SP products
	G = Radial tab, riveted and soldered G1 = Radial tab, riveted and <u>no</u> solder
AS	DS = Standard dielectric coating and silver metalized ends
	N = No-arc terminal and dielectric coating NO = No-arc terminal with oil resistant coating
	DG = Radial tab, riveted and soldered with dielectric coating DG1 = Radial tab, riveted and <u>no</u> solder with dielectric coating
	GO = Radial tab, riveted and soldered with oil resistant coating
	TO = Soldered end and oil resistant coating
A	No Suffix = Standard nickel metalized ends
	D = Dielectric coating DG = Radial tab, riveted and soldered with dielectric coating
	N = No-arc terminal and dielectric coating NO = No-arc terminal with oil resistant coating
	DG = Radial tab, riveted and soldered with dielectric coating DG1 = Radial tab, riveted and <u>no</u> solder with dielectric coating
	GO = Radial tab with oil resistant coating
TO = Soldered end and oil resistant coating	

Contact Information

KANTHAL

Kanthal Global, 495 Commerce Drive, Ste. 7
Amherst, NY 14228-2311, USA

Phone: (716) 691-4010 Fax: (716) 691-7850

Toll-Free: 877-GLOBAL-2 (877-456-2271)

E-mail: sales.global@kanthal.com

Website: www.global.com

High Voltage Resistors – High Power Resistors – High Energy Resistors

Series 800 and 1000 Tubular Resistors are available in a wide variety of sizes and terminations from 2" to 24" in length and 1/2" to 2" in diameter. These resistors can handle up to 1000 watts, 165 kJ and 165 kV in resistance values from 1 ohm to 1 megohm.

Electrical Specifications

Length and Diameter	Type	Resistance Available (ohms) Min. to Max.		Average Power @ 40°C (watts)	Peak* Energy (joules)	Peak* Voltage** (volts)
2" x 1/2"	884SP	1.0	200	22.5	250	1,000
2 1/2" x 3/4"	885SP	1.0	130	45	250	1,000
	885AS	6.0	1200	15	2,800	8,000
	885A	1500	220K	15	750	3,750
5" x 3/4"	886SP	1.0	330	90	500	4,000
	886AS	15.0	3300	30	7,000	20,000
	886A	3900	390K	30	1,500	10,000
6" x 1"	887SP	1.0	330	150	1,600	4,000
	887AS	12.0	3300	50	13,000	30,000
	887A	3900	390K	50	6,000	12,000
6" x 1 1/2"	1026AS	5.0	1200	70	30,000	30,000
8" x 1"	888SP	1.0	390	190	2,100	6,000
	888AS	15.0	3900	75	16,500	45,000
	888A	4700	470K	60	7,500	15,000
8" x 1 1/2"	1028AS	6.5	1875	100	46,000	45,000
12" x 1"	889SP	1.0	680	275	3,200	10,000
	889AS	25.0	6800	100	27,000	75,000
	889A	8200	680K	90	12,500	25,000
12" x 1 1/2"	1032AS	9.0	2500	150	75,000	75,000
18" x 1"	890SP	1.0	1000	375	4,200	16,000
	890AS	40.0	10K	150	43,000	120,000
	890A	12K	1M	125	20,000	40,000
18" x 1 1/2"	1038AS	15.0	3800	225	119,000	120,000
18" x 2"	891SP	1.0	450	750	15,000	16,000
24" x 2"	892SP	1.0	600	1000	17,500	22,000
24" x 1 1/2"	1044AS	20.0	4800	300	164,000	165,000

* Allowable peak energy/voltage will depend on the resistance value. Consult factory.

** Derate by 50% with oil resistant coating on Type AS resistors. Energy ratings are based on pulses <10 milliseconds. Type SP ratings can be substantially greater for longer pulses. Consult factory.

Dimensions – Inches

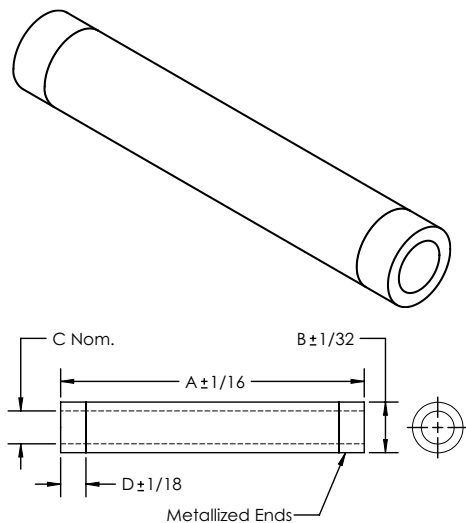

Type	A	B	C (SP & AS)	C (A)	D
884 SP	2.0	0.50	0.22	–	0.25
885 SP, AS, & A	2.5	0.75	0.50	0	0.50
886 SP, AS, & A	5.0	0.75	0.50	0	0.62
887 SP, AS, & A	6.0	1.00	0.75	0.5	0.50
888 SP, AS, & A	8.0	1.00	0.75	0.5	0.88
889 SP, AS, & A	12.0	1.00	0.75	0.5	0.88
890 SP, AS & A	18.0	1.00	0.75	0.5	0.88
891 SP	18.0	2.00	1.50	–	1.00
892 SP	24.0	2.00	1.50	–	1.00
1026 AS	6.0	1.50	1.00	–	0.50
1028 AS	8.0	1.50	1.00	–	0.88
1032 AS	12.0	1.50	1.00	–	0.88
1038 AS	18.0	1.50	1.00	–	0.88
1044 AS	24.0	1.50	1.00	–	0.88

Special sizes are available. Consult factory.

Termination Metals

Electrical connection to the resistive bodies of resistors is made by metal end bands. The standard metal is aluminum for Type SP, silver for Type AS and nickel for Type A. Special terminations of brass, copper or soldered ends are also available.

Mounting Clips

In most cases, connections to the resistors may be made by using these stock clips.

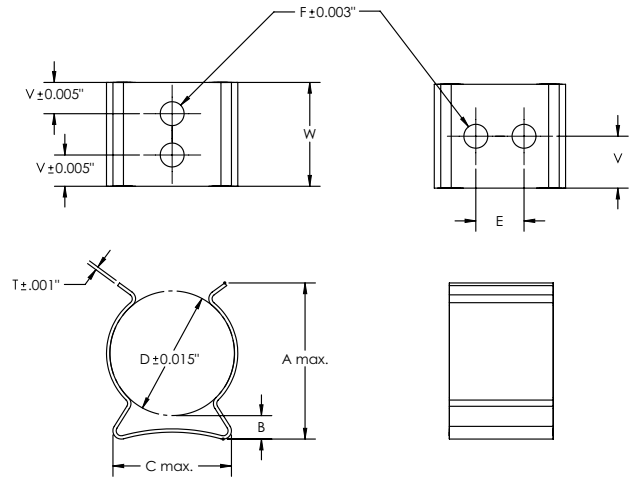

Dimensions — Inches

Part No.	Resistor OD	Holes	A	B	C	D	E	F	T	V	W
35370	1/2	1	0.620	0.090	0.560	0.500	N/A	0.093	0.020	0.188	0.375
35267	3/4	1	0.940	0.155	0.830	0.750	N/A	0.144	0.020	0.312	0.625
35268	1	2	1.230	0.170	1.070	1.000	N/A	0.128	0.024	0.156	0.625
35371	1 1/2	2	1.650	0.100	1.650	1.500	0.925	0.103	0.032	0.250	0.500
35269	2	2	2.375	0.544	1.080	2.000	0.375	0.125	0.043	0.375	0.750

Material: Beryllium Copper Finish: Electro Tin Plate

Aluminum Connector Caps

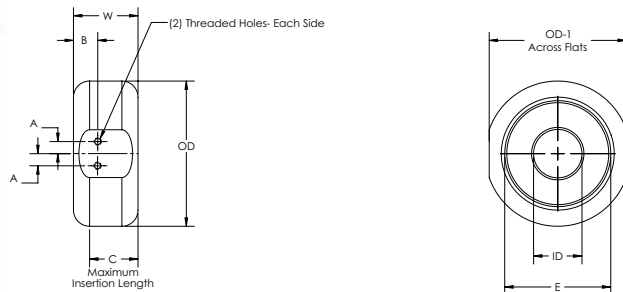
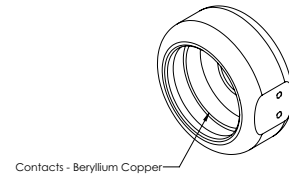

Dimensions — Inches

Part No.	Resistor Diameter	OD	OD-1	W	E	ID	A	B	C	Threaded Holes
36075	3/4	1 1/2	1 3/8	3/4	0.830	3/8	3/16	3/16	.50	M3 x .5P x 3/16" DP
36100	1	1 3/4	1 5/8	1	1.080	1/2	3/16	3/8	.75	M3 x .5P x 3/16" DP
36150	1 1/2	2 1/4	2 1/8	1	1.580	3/4	3/16	3/8	.75	M4 x .7P x 3/16" DP
36200	2	3	2 3/4	1 1/8	2.080	1	5/16	7/16	.88	M5 x .8P x 1/4" DP

Optional No-Arc Termination

“N” Suffix



Dimensions — Inches

D1	D2	D	W
1	1.56	1	3/4
1 1/2	1.84	1	3/4

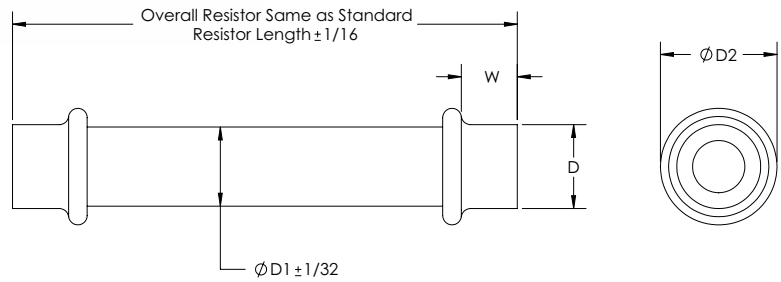

Optional Radial Tab Termination

“G1” suffix - riveted only

“G” suffix - riveted with solder



Dimensions — Inches

D	W1	A	B
1/2	3/16	17/32	0.062
3/4	3/8	25/32	0.156
1	3/8	25/32	0.156
1 1/2	3/8	25/32	0.156
2	5/8	1.25	0.281

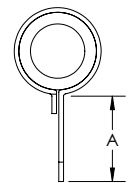
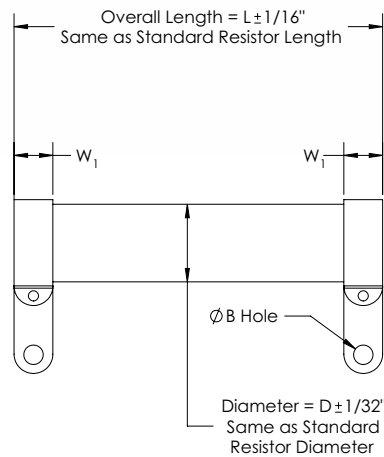

Characteristics	Type SP	Type AS	Type A
Operating Temperature (I)	-55°C to +350°C	-55°C to +230°C	-55°C to +230°C
Resistance Temperature Coefficient	+0.2 to -0.08 %/°C	+0.0 to -0.08 %/°C	+0.0 to -0.02 %/°C
Voltage Coefficient Max. % per kilovolt per inch active length	-1.0%	-1.0%	—
Short Time Overload Max. % change after 10 cycles of 1000% rated power 5 sec. On, 90 sec. Off	± 5%	± 2%	—
Load Life Max. % change after 1,000 hours at rated power	± 5%	± 5%	—
Thermal Shock Max. % change after 10 cycles -55°C to +125°C	± 3%	± 3%	—
Moisture Resistance Max. % change when tested per MIL-STD-202, Method 103	± 5%	± 5%	± 5%

(I) Note: When required, Type SP material can withstand short periods of use at red-heat conditions, i.e. up to 550°C to 600°C

Typical Physical Properties	SP Resistors	AS Resistors	A Resistors
Density	2.2 - 2.4 gm/cc	2.2 - 2.6 gm/cc	2.2 - 2.6 gm/cc
Specific Heat	0.24 - 0.26 cal/gm · °C	0.23 - 0.25 cal/gm · °C	0.23 - 0.25 cal/gm · °C
Thermal Conductivity	0.14 - 0.16 cal/cm · °C/sec	0.003 - 0.006 cal/cm · °C/sec	0.003 - 0.006 cal/cm · °C/sec

Power Rating Curves

Power ratings are based on maximum allowable surface temperature in still air at 40°C ambient temperature.

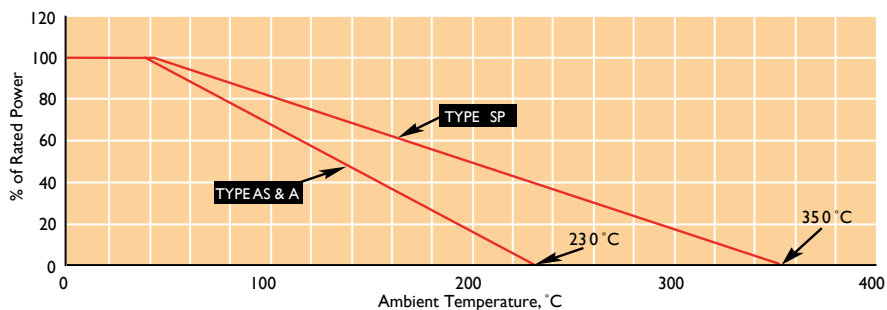

Resistor Surface Temperature Rise Versus Power

(Curve is Typical for Resistor Midpoint with Horizontal Orientation in Still Air)

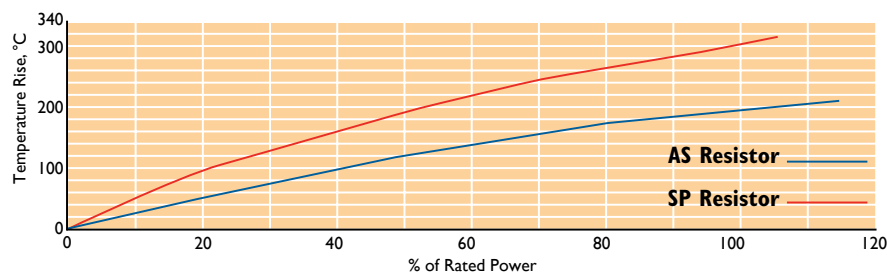

Disclaimer: The information contained in this document is for illustrative purposes only. The data and examples are only general recommendations, and not a warranty or a guarantee that such data will function in individual/specific cases. The purchaser of a Kanthal product has the responsibility to control the applicability of Kanthal's products in a specific application before using them.

© KANTHAL is a registered trademark of Kanthal Group companies in Sweden and other countries.

Kanthal – a Member of the Sandvik Group

The Sandvik Group is a global high technology enterprise with 41,700 employees and annual sales of approximately SEK 72 billion. Sandvik spends about 4 percent of its turnover on research and development. As a member of the Sandvik Group, Kanthal has full access to world-class competence within materials and process technology, as well as Sandvik's R&D-center in Sweden, which is one of the most distinguished in the world. Through Sandvik's global sales organization Kanthal is represented in 130 countries.

KANTHAL